

OBVIOUSLY —
— INVISIBLE

DATASHEET
X-CELL RT 3.0

MAGNETOELASTIC BOTTOM BRACKET
TORQUE AND CADENCE SENSOR

thun[®]

INTRODUCTION

This datasheet describes the details of a bottom bracket torque and cadence sensor system.

PRODUCT/APPLICATION

The torque sensor consists of two main components: a magnetized spindle and an electronic torque sensor unit resting safely overmoulded in the bb-set's composite sleeve. The patented non-contact sensor technology utilizes fundamental mechanical and magnetic properties to measure the applied torque to the torque transmitting spindle. The electronic control unit converts magnetic field changes in the spindle into an analogue output signal. These measurements are highly linear, repeatable and accurate even under harsh environmental and extended operation conditions.

The cadence sensor also consists of two components: a magnetic pole ring featuring 16 magnetic poles and a sensor unit featuring two separate Hall-sensors. These two sensors are also embedded into the bb-set's sleeve in an offset position to each other which causes the phase shift of 90° to generate one digital sine and one digital cosine signal. By means of intelligent evaluation of these signals the rotational direction can be determined. Due to the presence of two Hall-sensors that each sense 16 poles a total resolution of 32 signals is possible.



DELIVERABLES (AS ONE PRE-ASSEMBLED SENSOR UNIT)

- 1 x magnetized, square-tapered spindle
- 2 x ball bearings
- 1 x magnetic pole ring for cadence sensing
- 1 x sensor housing with integrated torque and cadence sensor technology
- 1 x cable with connector
- 1 x threaded composite cup on the right side
(optionally featuring a pre-assembled 365 RUBBER seal)
- 1 x spacer (only applies to sensors for 73 mm and 83 mm housings)

DELIVERABLES (LOOSE)

- 1 x threaded composite cup for the left side
(optionally featuring a pre-assembled 365 RUBBER seal)

TECHNICAL SPECIFICATIONS

GENERAL ATTRIBUTES OF BB-SENSOR

ATTRIBUTES	DESCRIPTIONS/VALUES
Certified as per	EN 15194:2017 and Part 2, ISO 4210-8:2014 mountain bikes
Surface of spindle	A2B
Type of ball bearings	61902 2RS
Material of composite cups	Composite A (left cup) and Composite D (right cup)
Thread dimensions of composite cups	BS 1.375" x 24
Compatible crank sets/arms	All variants compatible with square tapers certified as per ISO 6695 - 2015-12-15
Compatible assembly key	Standard Shimano® assembly key
Compatible retightening key	PEDRO'S® (item no. 6460270)
Material of sensor sleeve	Composite and Macromelt®
PCB	Nano-coated
Standard cable length	220 mm net length from outlet of bb-set's sleeve to connector (if you require an extended cable length please refer to the information regarding the STANDARDIZED INTERFACE SYSTEM in our catalogue and on www.thun.de)
Standard connector	Higo Mini Z509 FG Male (if you require a different connector please refer to the information regarding the STANDARDIZED INTERFACE SYSTEM in our catalogue and on www.thun.de)
IP rating of sensor	IP 55 as per EN 60529*
IP rating of connector	IP 66 as per EN 60529*
Operating temperature	-40 °C to +80 °C
Electromagnetic Compatibility (EMC)	Certified as per EN 15194:2017



* IP rating and general resistance against water can only be optimally achieved when the sensor/connector is not constantly emerged in standing water. Hence, it is recommended to ensure that water can exit the e-bike frame's bb-housing (i.e. by drilling a centred drainage hole with a diameter of approx. 5 mm). Also, it is important that all connectors that are directly or indirectly connected to the sensor are either fully protected from water or feature at least an IP X6 rating or higher.

PINOUT AND MAIN DETAILS ON ELECTRONICS AND SIGNALS

PINOUT	ELECTRONICS	SIGNALS	
		BASIC DETAILS	
Red/Pin no. 1	Power	6 V - 16 V, max. 20 mA	
White/Pin no. 2	Torque	0 V - 5 V	Analogue signal, offset +2.5 V at 0 Nm (+/- 10 mV/Nm), bandwidth: 250 Hz at -3 dB
Blue/Pin no. 3	Cadence 2*	0 V - Controller VCC**	Digital signal, cosine square wave, 0 V/open collector, 16 impulses/rotation
Green/Pin no. 4	Cadence 1	0 V - Controller VCC**	Digital signal, sine square wave, 0 V/open collector, 16 impulses/rotation
Black/Pin no. 5	Ground	0 V	

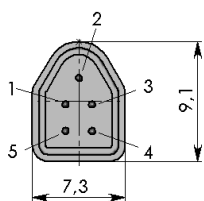

ADDITIONAL DETAILS ON SIGNALS REGARDING CADENCE SENSORS (CADENCE 1 AND CADENCE 2)

ATTRIBUTES	EXPLANATIONS	VALUES
Accuracy		$\pm 3^\circ$ ($\pm 0.8\%$) per full rotation (360°)
Resolution	Expected angle sensitivity	11.25°
Phase shift nominal		90°
Phase shift tolerance		$\pm 30^\circ$

SIGNAL CHARACTERISTICS

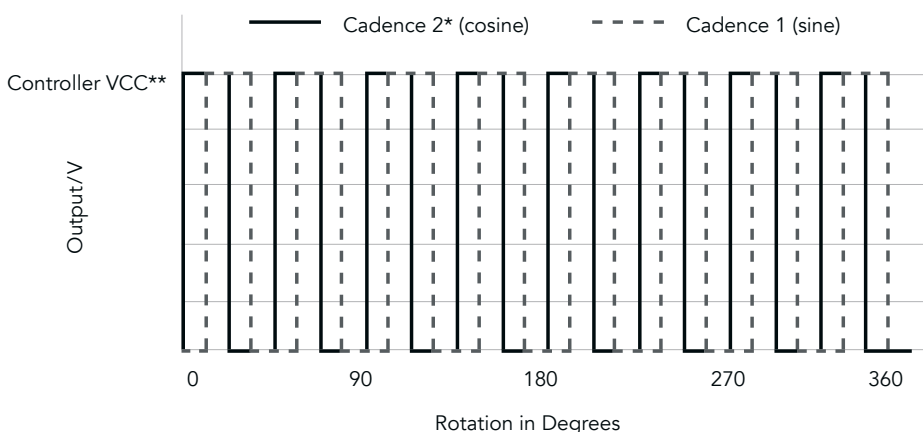

* Please make sure that the cadence 2 signal (cosine) is embedded in the controller as the leading cadence signal to detect the correct direction of rotation!

** VCC = Voltage supplied by controller (value depends on the controller model).

ADDITIONAL DETAILS ON SIGNALS REGARDING TORQUE SENSOR

ATTRIBUTES	EXPLANATIONS	VALUES
Accuracy		$\pm 2.5\%$ of FS (± 200 Nm)
FS measurement range	Measurement range output signal positive torque	200 Nm
	Measurement range output signal negative torque	-200 Nm
SH torque	Expected maximal mechanical load	250 Nm
Rotational Signal Uniformity	Rotational signal variation, peak-to-peak value	$< \pm 1\%$ of FS
Max SH rotational speed	Maximal rotational speed	200 rpm
Nom SH rotational speed	Maximal rotational speed	60 rpm

SIGNAL CHARACTERISTICS

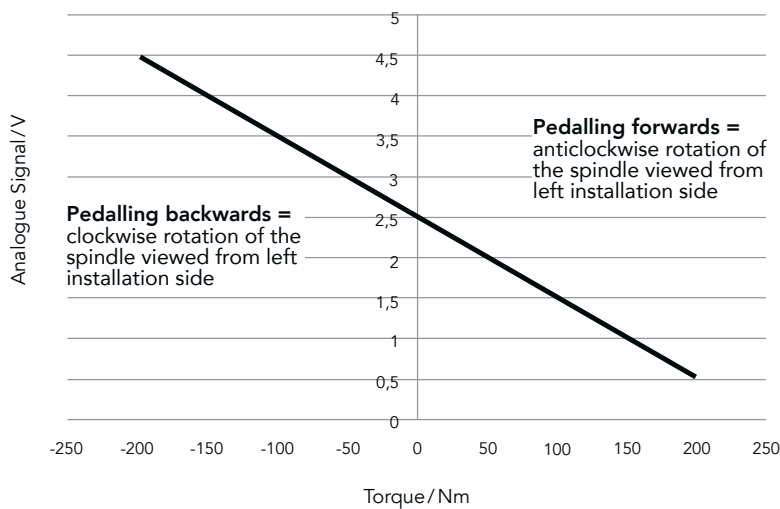

DO NOT DEGAUS! DO NOT TOUCH WITH MAGNETS, MAGNETIC TOOLS (I.E. MAGNETIC SCREW DRIVERS) OR MAGNET FIXTURES!

ADDITIONAL DETAILS ON ELECTRONICS

(FOR EACH MEASUREMENT CHANNEL) **REGARDING TORQUE SENSOR**

ATTRIBUTES	EXPLANATIONS	VALUES
Negative output signal	Output signal for -FS signal	0.5 V
Positive output signal	Output signal for +FS signal	4.5 V
Characteristic value	Expected characteristics value (final value given in calibration certificate)	± 10 mV/Nm
"Centre" position output	Output signal when primary sensor is in neutral (or centre) position and no mechanical forces are applied	2.5 V
"Zero" offset signal	One-time offset of the "zero" signal caused by assembly	± 100 mV
Signal-to-noise ratio	Output signal noise level	5 mV
Sensor signal bandwidth	Frequency of sensor system signal bandwidth	250 Hz
Start-up current	Required start-up supply current (excluding the current absorbed by required protection circuits)	<100 mA
Operating current	Nominal operating current	<30 mA
Supply voltage range	Provided single supply voltage (regulated and reverse protect)	6 V - 16 V

ADDITIONAL DETAILS ON ELECTRONICS (CONNECTION PLAN) REGARDING CADENCE SENSORS (CADENCE 1 AND CADENCE 2)

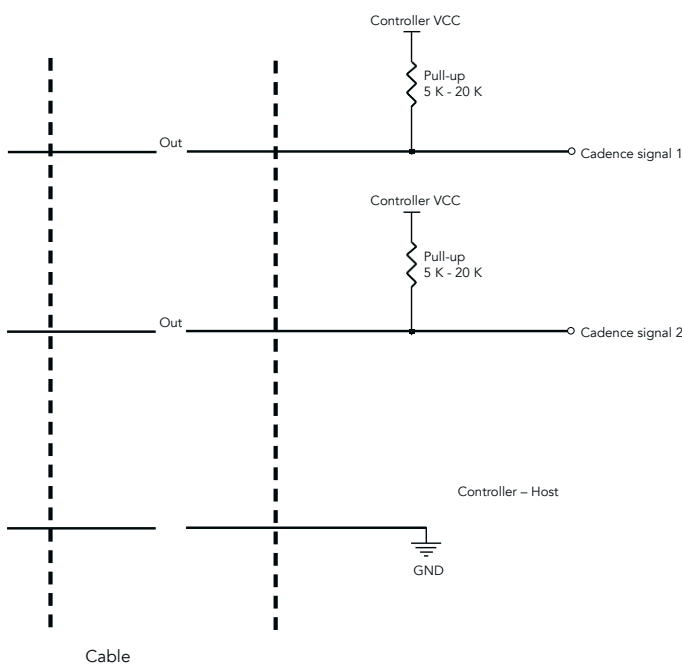

DIMENSIONS AND AVAILABLE LENGTHS

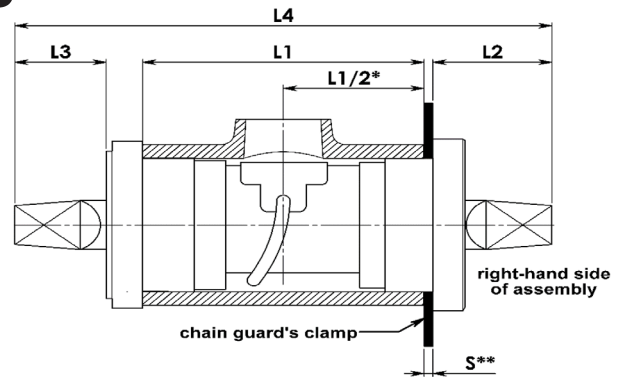

HOUSING LENGTH	TYPE	REFERENCE SIZE	DIMENSIONS RIGHT-HAND SIDE OF ASSEMBLY	DIMENSIONS LEFT-HAND SIDE OF ASSEMBLY	SPINDLE LENGTH
L1 ±0.50 mm [mm]			L2** ±0.50 mm [mm]	L3** ±0.50 mm [mm]	L4 ±1.00 mm [mm]
68.00	120 K***	114, 115, 116	24.40	22.60	120.00
	122 L	119	26.40	20.60	122.00
	128 K	123	28.40	24.60	128.00
	128 L	131	30.40	22.60	128.00
	133 L	133	34.90	23.95	133.65
73.00	129 K	119	26.40	22.60	129.00
	134 K	123	28.40	24.60	133.00
	134 L	131	30.40	22.60	133.00
	137.25 L	133	33.65	23.60	137.25
	139 L	133	34.90	24.75	138.65
	142.35 L	----	38.75	23.60	142.35
83.00	137.5 L	122	26.60	20.90	137.50
	139 L	123	28.40	20.60	139.00
	143 L	131	30.40	22.60	143.00

* BB-housing needs to be welded into the frame in a centered position.

** When assembled with chain guard kindly add „S“ to „L2“ (L2 + S) and subtract „S“ from „L3“ (L3 - S).

*** Type only available with X-CELL RT 2.0 cups.

Corporate identity and graphic design: Anika Freytag
3D renderings: Medienrausch GmbH & Co. KG
Claim development: TXT Konzeption & Text Thomas Volberg

Rev. 004/02.2022

© Alfred Thun GmbH. All rights reserved.

Any reprinting/redistribution of this work without the express
written consent is prohibited.

Errors and omissions excepted.

Content is confidential.

thun[®]